



**CITY OF AUSTIN
STANDARD PRODUCTS LIST**
for
32 INCH MANHOLE COVER CASTING SETS

USING DEPARTMENT: Austin Water

PREPARED BY: David Rinn

ISSUED: 07/01/97

REVISED BY: Jeff A. Kyle, P.E.

REVISED: 07/01/23

- DESCRIPTION:** Manhole Rings and Covers (32" diameter cover) shall comply with the following:
1. Ring shall be Gray Cast Iron, ASTM A48, Class 30B or higher or Ductile Iron, ASTM A536, Grade 60-40-18 or higher.
 2. Cover shall be Ductile Iron, ASTM A536, Grade 60-40-18 or higher.
 - a. Cover marked "Sanitary Sewer" or "Potable Water" or "Reclaimed Water" as ordered.
 - b. Weight shall be as required for HS-20 loading with appropriate safety factors and as shown on manufacturer's drawings and on casting.
 - c. Weight of cover shall be 175 lbs plus or minus 3 percent.

LISTING DATE	MANUFACTURER	PRODUCT IDENTIFICATION/COMMENT	APPROVAL
07/01/97	EJ (formerly East Jordan Iron Works) 216 E. 6 th Street San Angelo, TX 76901 (formerly Western Iron Works and Vulcan Foundry)	Bolted Cover (Part No. V2432-1) Non-Bolted Cover (Part No. V1432-1) Bottom Flange Ring (Part No. V2432) Top Flange Ring (Part No. V1816 ZPT)	K. Flowers
10/01/97	CALCUTTA FOUNDRY, LTD / INDIA SIGMA CORP. 5000 Askins Lane Houston, TX 77346	Bolted Cover (Part Nos. MH15761N, MH15761PW, MH15761RW) Bolted Bottom Flange Ring (Part No. MH13/15/16/19-76) Non-Bolted Cover (Part Nos. MH15751N, MH15751PW, MH15751RW) Non-Bolted Bottom Flange Ring (Part No. MH13/15/16/19-75)	R. Lamb
01/04/99	SHREE RAM FOUNDRY / INDIA (CI Ring) and GEMUS FOUNDRY / INDIA (DI Cover) STAR PIPE PRODUCTS CO. 4018 Westhollow Parkway Houston, TX 77982	Bolted Cover (Part No. MHCAUSSSWT-DI) Bolted Bottom Flange Ring (Part No. MHAUSTINR-WT) Non-Bolted Cover (Part No. MHCAUSSS-DI) Non-Bolted Bottom Flange Ring (Part No. MHAUSTINR)	R. Lamb
07/01/04	VICTORY IRON WORKS, LTD / INDIA ACCUCAST 415 South 21 st Avenue Waco, TX 76706	Bolted Cover (Part Nos. 260605, 260608, 260609) Bolted Bottom Flange Ring (Part No. 260605R) Bolted Top Flange Ring (Part No. 260754R) Non-Bolted Cover (Part Nos. 260601, 260602, 260604) Non-Bolted Bottom Flange Ring (Part No. 260601R) Non-Bolted Top Flange Ring (Part No. 260760R)	R. Lamb
10/01/19	NEENAH FOUNDRY, CO. 2121 Brooks Ave. Neenah, WI 54956	Bolted Cover (Part No. 1931-5000) Bolted Bottom Flange Ring (Part No. 1932-2333) Bolted Top Flange Ring (Part No. 1931-2332) Non-Bolted Cover (Part No. 1931-5004) Non-Bolted Bottom Flange Ring (Part No. 1932-2336) Non-Bolted Top Flange Ring (Part No. 1931-2331)	J. Kyle



**CITY OF AUSTIN
STANDARD PRODUCTS LIST
for
32 INCH MANHOLE COVER CASTING SETS**

LISTING DATE	MANUFACTURER	PRODUCT IDENTIFICATION/COMMENT	APPROVAL
04/01/20	SIP INDUSTRIES 8876 Gulf Freeway, Ste 500 Houston, TX 77017	Bolted Cover (Part No.4045C) Bolted Bottom Flange Ring (Part No. 4074R) Bolted Top Flange Ring (Part No. 4085R) Non-Bolted Cover (Part No. 4046C) Non-Bolted Bottom Flange Ring (Part No. 4082R)	J. Kyle

NOTES:

1. Must be compliant with the above Description and with the attached diagrams. Machined surfaces shall be true to dimensions as shown. No principal dimensions shall vary by more than 1/8" from the dimensions shown on the attached diagrams. Rocking or interference in fit between an interchanged ring and cover will not be acceptable.
2. Manufacturer's application to the Standards Committee shall include independent laboratory report on proof load test. Load test shall meet AASHTO M-306. Proof load test shall be performed by a domestic laboratory and test results shall be sealed by Texas-licensed professional engineer. Utility will require certification every 2 years stating that there has been no change in design or manufacture of these castings. If variations from manufacturer's weights are found, a new test by an independent laboratory of a randomly selected casting set will be required at the manufacturer's expense.
3. All manholes not located in paved areas shall have bolted covers.

LATEST REVISIONS (since 01/01/23):

1. Updated address for Sigma Corp.

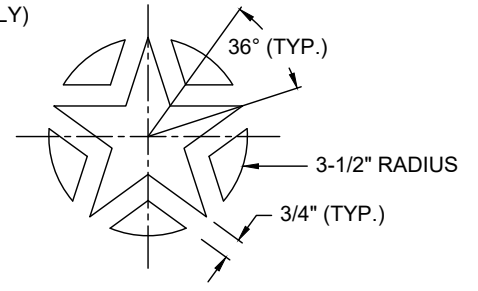
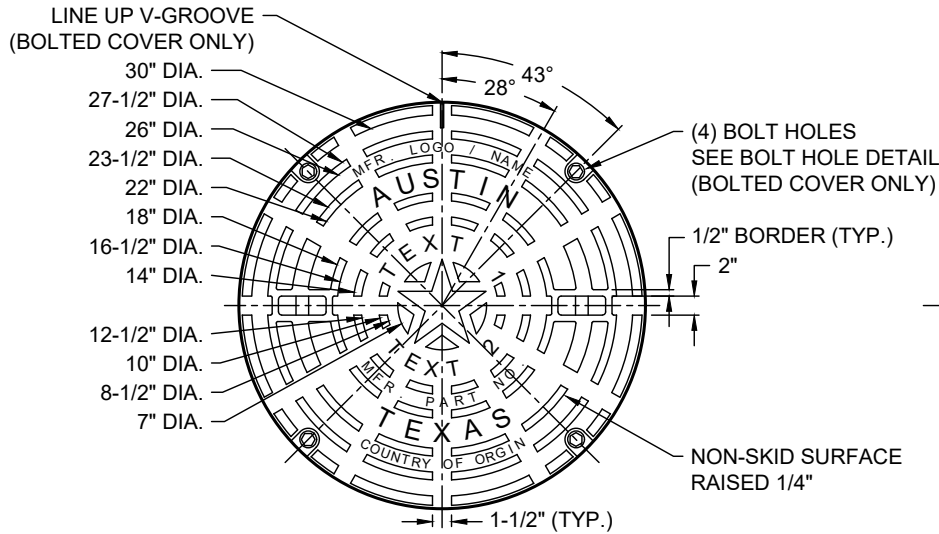

USE	TEXT 1	TEXT 2
WASTEWATER	SANITARY	SEWER
DRINKING WATER	POTABLE	WATER
RECLAIMED WATER	RECLAIMED	WATER

COVER PLAN VIEW

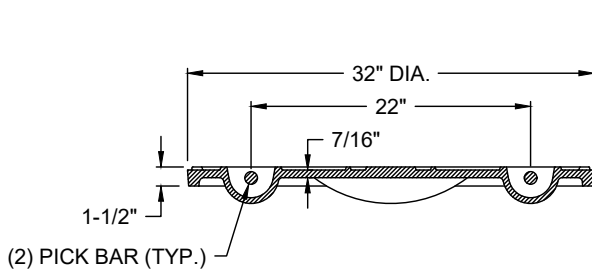

COVER SECTION VIEW

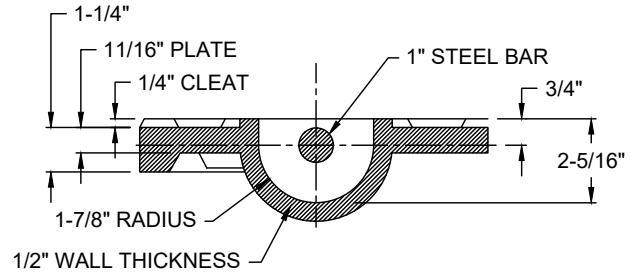

PICK BAR DETAIL

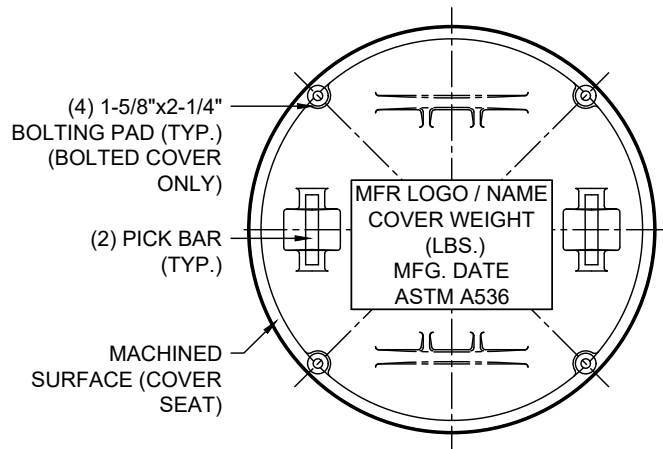

COVER BOTTOM VIEW

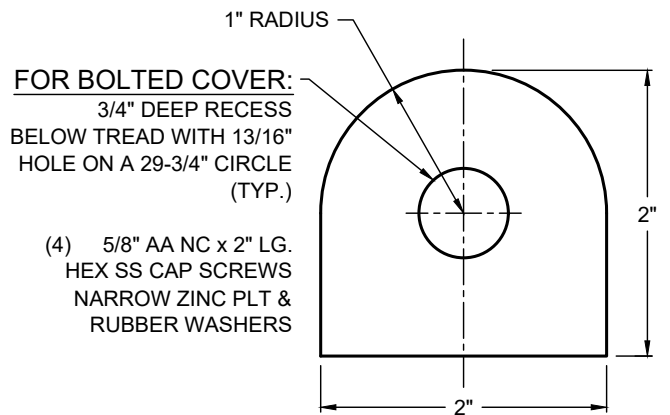

BOLT HOLE DETAIL

TEXT REQUIREMENTS:

1. USE TYPE SHALL BE CAST INTO COVER IN 1-1/4" LETTERS AS SHOWN IN TABLE.
2. MANUFACTURER LOGO OR NAME (3/4" LETTERS), "AUSTIN" "TEXAS" (1-1/2" LETTERS), MFR. PART NO. (3/4" LETTERS), AND COUNTRY OF ORIGIN (1/2" LETTERS) SHALL BE CAST ON TOP OF COVER AS SHOWN.
3. MFR. LOGO OR NAME, COVER WEIGHT (LBS.), MANUFACTURE DATE, AND "ASTM A536" SHALL BE CAST ON BOTTOM OF COVER (3/4" LETTERS) AS SHOWN.

**32-INCH
MANHOLE COVER**

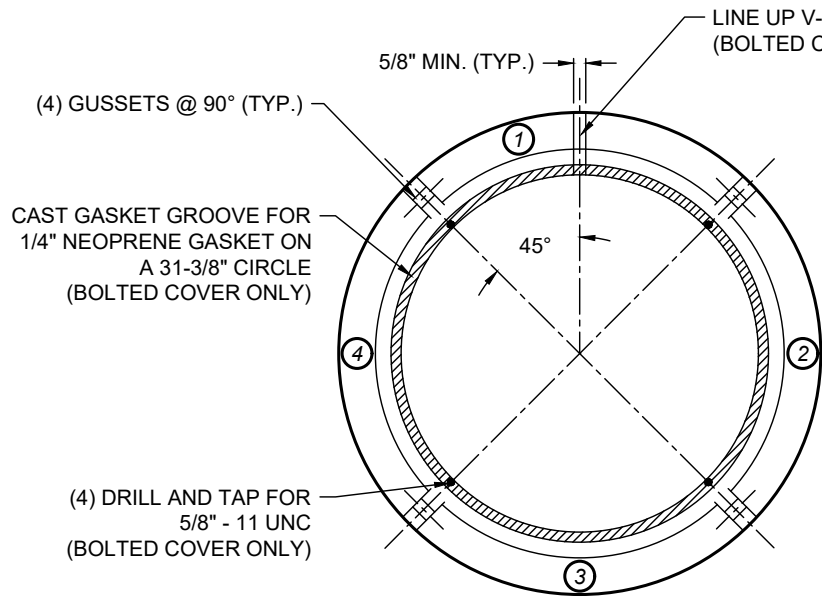

CAST INTO TOP OF RING (3/4" LETTERS)

- ① MANUFACTURER'S LOGO OR NAME
- ② MANUFACTURER'S PART NO.
- ③ DATE OF MANUFACTURE
- ④ COUNTRY OF ORIGIN

CAST INTO BOTTOM OF RING

- *AASHTO M306 AND
- *ASTM A48 CL35B OR ASTM A536 60-40-18

RING PLAN VIEW

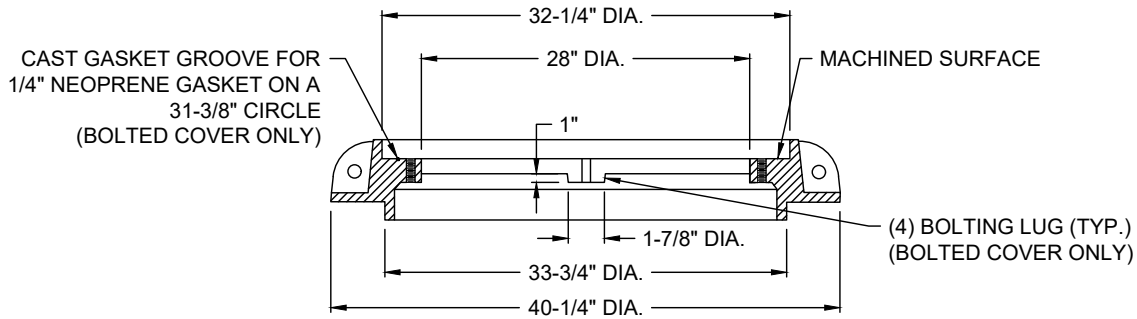

RING SECTION VIEW

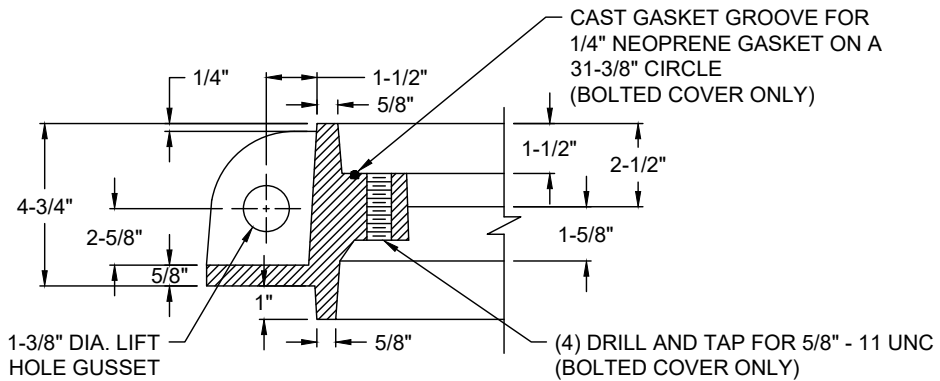

LIFT HOLE DETAIL

**32-INCH BOTTOM FLANGE
MANHOLE RING**

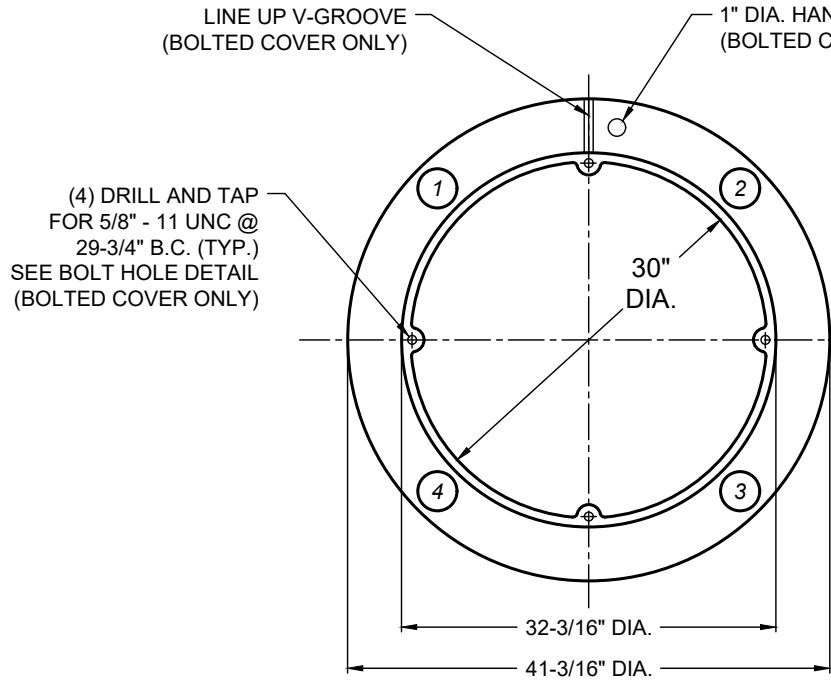

CAST INTO TOP OF RING (3/4" LETTERS)

- ① MANUFACTURER'S LOGO OR NAME
- ② MANUFACTURER'S PART NO.
- ③ DATE OF MANUFACTURE
- ④ COUNTRY OF ORIGIN

CAST INTO BOTTOM OF RING

- *AASHTO M306 AND
- *ASTM A48 CL35B OR ASTM A536 60-40-18

RING PLAN VIEW

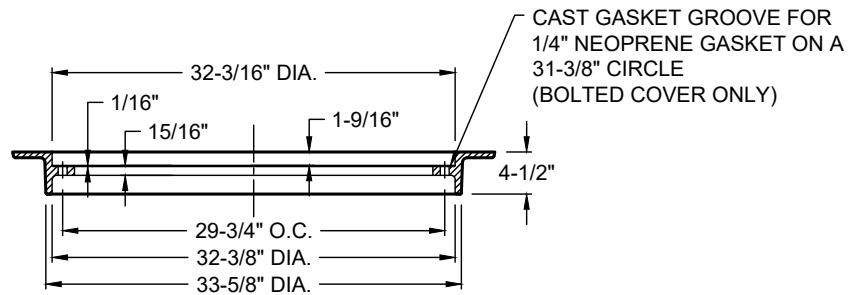

RING SECTION VIEW

32-INCH TOP FLANGE
 MANHOLE RING